

(No Model.)

3 Sheets—Sheet 1.

P. NEWMAN.
WOOD TURNING LATHE.

No. 444,457.

Patented Jan. 13, 1891.

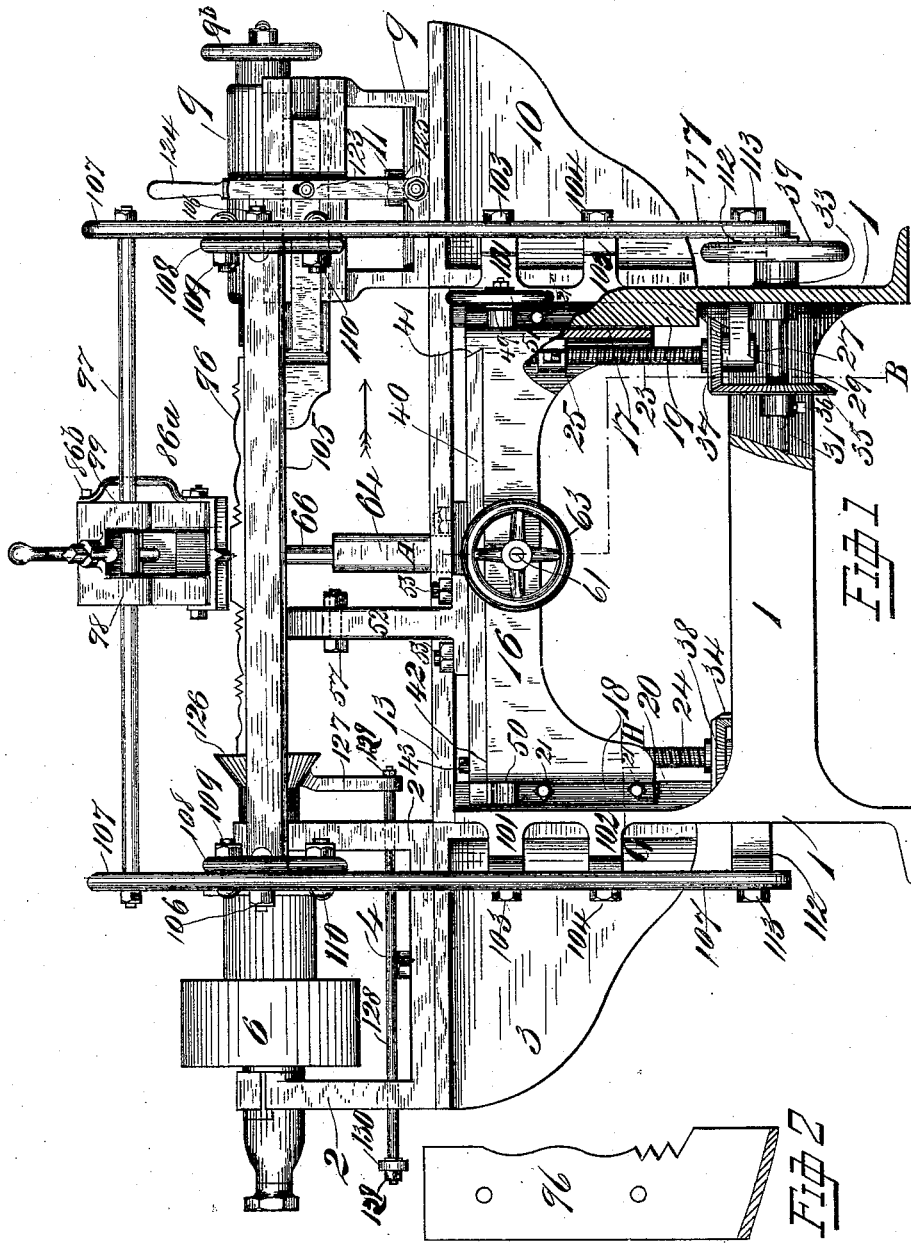

Witnesses

George Masson
Paul Dough

Inventor

Peter Newman

By his Attorney *Thompson & Rice*

(No Model.)

3 Sheets—Sheet 2.

P. NEWMAN.
WOOD TURNING LATHE.

No. 444,457.

Patented Jan. 13, 1891.

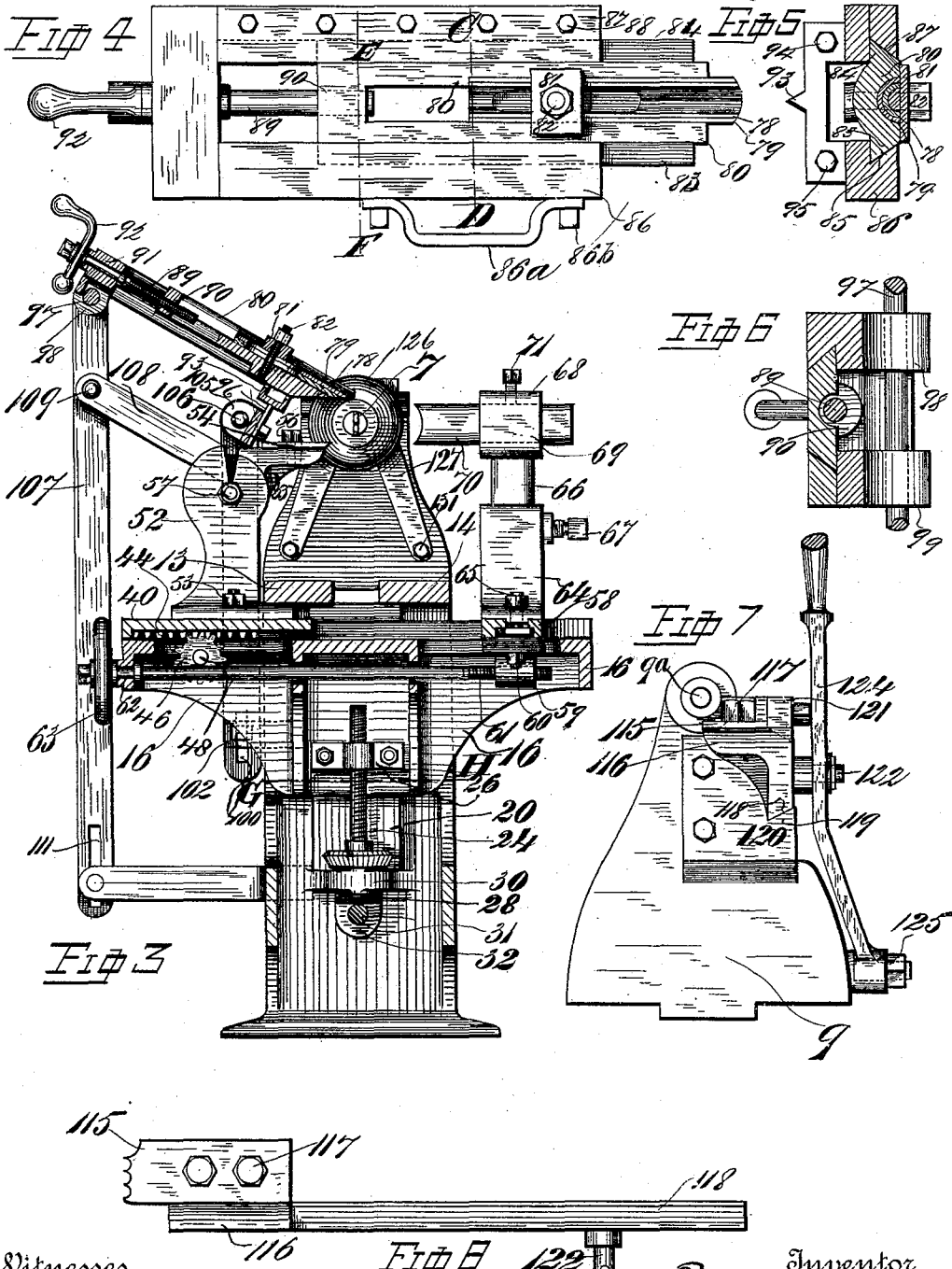

Witnesses
George Masson
Paul Hough

Inventor
Peter Newman
 By his Attorney
Thompson & Rice

(No Model.)

3 Sheets—Sheet 3.

P. NEWMAN.
WOOD TURNING LATHE.

No. 444,457.

Patented Jan. 13, 1891.

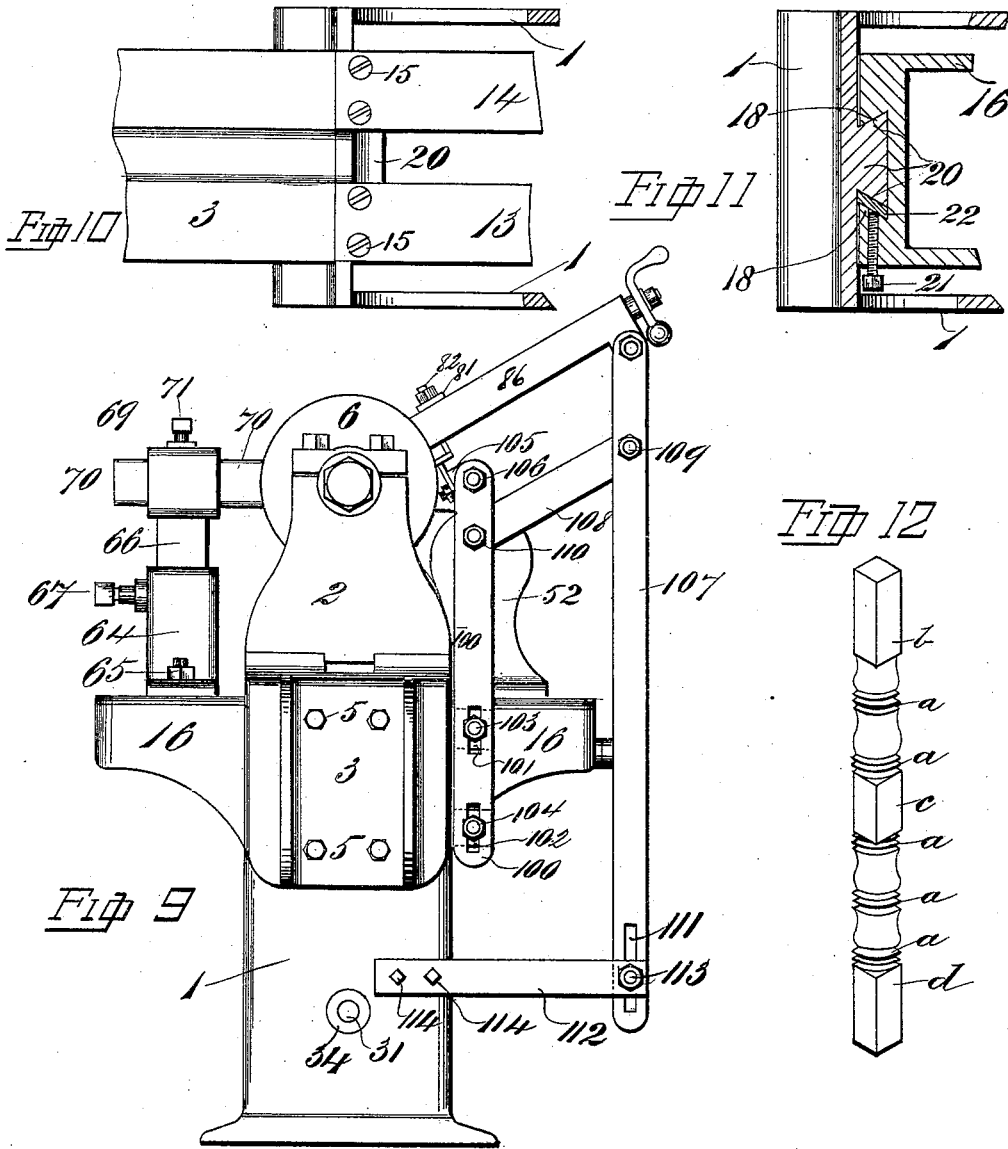

Witnesses

George Messinger
Carlough

Inventor
Peter Newman

By his Attorney
Chompson & Bell

UNITED STATES PATENT OFFICE.

PETER NEWMAN, OF INDIANAPOLIS, INDIANA, ASSIGNOR OF ONE-HALF TO
GEORGE MASSONNE, OF SAME PLACE.

WOOD-TURNING LATHE.

SPECIFICATION forming part of Letters Patent No. 444,457, dated January 13, 1891.

Application filed May 8, 1890. Serial No. 351,011. (No model.)

To all whom it may concern:

Be it known that I, PETER NEWMAN, a citizen of the United States, residing at Indianapolis, in the county of Marion and State of Indiana, have invented new and useful Improvements in Wood-Turning Lathes, of which the following is a specification.

My invention relates to improvements in ornamental wood turning and finishing machines or lathes.

Special back-knife lathes, designated "gage-lathes," have been used to turn ornamental posts, columns, &c. This class of wood-turning lathe has been found to be objectionable in use, for the reason that the knife or cutting-tool with which said lathes are provided is expensive to maintain in repair, it being formed like the contour of the ornamental column to be turned, which form must be preserved in the operation of grinding and sharpening; also, a special knife must be provided for each and every different design of contour of column; also, those classes of columns or rails having portions of their length prismatic (particularly those having such a form at or near the middle of their lengths, as stair-balusters) cannot be formed on such a machine.

The object of my invention is to overcome these aforementioned objections, and also to provide a simple, durable, and cheap machine; also, means for turning rosettes or other similar ornaments; also, means for adjusting the roughing-tool to any desirable angle. I attain these objects by the mechanism illustrated in the accompanying drawings, in which—

Figure 1 is a front elevation of the machine. Fig. 2 is a partial enlarged view of the contour former or gage. Fig. 3 is a sectional end elevation through the line A B. (See Fig. 1.) Fig. 4 is an enlarged plan view of the cutter-head. Fig. 5 is a cross-section of the same through the line C D. (See Fig. 4.) Fig. 6 is also a cross-section of the same through the line E F. (See Fig. 4.) Fig. 7 is an enlarged end view of the tail-stock looking in the direction of the arrow. (See Fig. 1.) Fig. 8 is a detail plan view of the rose-bit holder. Fig. 9 is an end elevation of the machine, showing

the supporting-bars of the cutter-head and the manner of adjusting the same. Fig. 10 is a part plan detail view of the removable ways, showing the manner of securing the same to the main frame. Fig. 11 is a detail section of the main frame through the lines G H, (see Figs. 1 and 3,) and Fig. 12 is a perspective view of a column turned by this machine.

In the accompanying drawings similar numbers and letters of reference refer to like parts throughout the several views, in which—

1 designates the main frame.

2 is the head-stock, of the usual form used on wood-turning lathes, removably secured to the end bracket 3 by the bolt 4, said bracket being secured to the frame 1 by the bolts 5. (See Fig. 9.)

6 designates the stepped or cone pulley, of the usual form, and 7 is the rotating center bit. (See Fig. 3.)

9 designates the tail-stock, also of the usual form and adjustably secured to the tail-bracket 10 by the bolts 11, said bracket being secured to the main frame 1 by bolts, as 5. (See Fig. 9.)

13 and 14 designate suitable parallel ways or bars removably secured to the frame 1 by the countersunk bolts 15.

16 designates the center raising and lowering table, having its ends 17 and 18 V-formed to neatly fit and slide on the correspondingly-formed ways 19 and 20.

21 are suitable set-screws for regulating the pressure of the key 22 on the said ways 19 and 20. (See Fig. 11.)

23 and 24 designate the raising and lowering screws of the center table screwed into the threaded nuts 25 and 26, said nuts secured to the said table by suitable bolts, said screws having their ends 27 and 28 journaled in the bearings 29 and 30, formed integral with the frame 1.

31 designates the screw-operating shaft, journaled in the bearings 32 and 33, formed on the frame 1, and provided with the bevel-wheels 34 and 35, firmly secured thereon by the set-screws 36 or other suitable device. Said bevel-wheels meshing with the bevel-wheels 37 and 38, secured on the screws 23 and 24, 100

constitute the raising and lowering mechanism of the table.

39 is a suitable hand-wheel firmly secured on the shaft 31 for operating the same.

40 designates the front transverse sliding table, having its ends adapted to neatly fit and to slide in the V-ways 41 and 42, the former way 41 being formed integral with the central table, and the latter 42 is adjustably secured to the said table by the set-screws 43 for the purpose of taking up the wear. On the bottom and near the ends of the table 40 are formed the racks 44 and meshing with the pinions 46, secured on the shaft 48, said shaft journaled at its ends in suitable bearings 49 and 50, formed on the center table and integral therewith, said shaft provided with a suitable hand-wheel 51, firmly secured thereon for the purpose of operating the table.

52 designates the finishing-bit rest, firmly and removably secured to the transverse table 40 by the bolts 53.

54 is a finishing-bit removably secured to the arm 55 by the bolt 56, said arm jointed to the rest 52 and adjustably and removably secured thereto by the binding-bolt 57.

58 designates the back transverse sliding table, also having its ends adapted to slide and neatly fit the before-mentioned V-ways 41 and 42 of the raising and lowering table 16. To the bottom of the table 58 is secured the threaded boss 59 by the bolts 60, said boss 59 adapted to receive the transverse screw 61, said screw journaled in the bearing 62, formed in the table 16, and provided with the hand-wheel 63 for rotating the same manually.

64 designates the steadying-rest, removably secured to the table 58 by the bolts 65, said rest chambered to receive the post 66 and provided with the set-screw 67 for clamping the said post when set to any desirable height. On the post 66 is formed the head 68, having the rectangular opening 69, adapted to receive the rest 70, and provided with the set-screw 71 for adjusting the same.

78 and 79 designate the primary forming-bits, secured to the holder 80 by the clamp 81 and the clamp-bolt 82.

On the sides of the holder 80 are formed the V's 83 and 84, said V's neatly fitting and adapted to slide in V-way 85, formed integral with the holder-frame 86, and the adjustable V-way 87, adjustably and removably secured by the set-screws 88.

89 designates the feed-screw, screwed into the boss 90, formed integral with the tool-holder 86 and journaled in the bearings 91, formed integral with the holder-frame and provided with the manual operating-handle 92, secured firmly to the end thereof.

93 designates the knife-edge of the tool-holder, adjustably and removably secured to the holder-frame 86 by the bolts 94 and 95, said knife-edge adapted to contact with the irregular profile of the former 96, and is maintained in its relative position by the guide-

rod 97, said rod embraced by and neatly fitting the holes formed in the lugs 98 and 99, integral with the frame 86.

100 designates the former-supporting bars, adjustably and removably secured to the lugs 101 and 102 by the bolts 103 and 104, (said lugs may be either formed integral with the frame or removably secured thereto,) and said supporting-bars having their former-holder 105 secured thereto by the bolts 106.

To the ends of the guide-rod 97 are secured the adjusting-bars 107, said bars held in their approximate vertical position by the upper radial bars 108, pivotally secured thereto by the bolts 109 and to the former supporting-bars by the bolts 110. Said adjusting-bars, having their bottom ends provided with the slots 111, are adjustably secured to the arms 112 by the clamping-bolts 113, said arms firmly secured to the frame 1 by the bolts 114. (See Fig. 9.)

115 designates the rose-cutter bit, secured to its holder 116 by the cap-bolts 117, said holder having the V-bearings 118 formed thereon and adapted to neatly fit and slide in the V-ways 119, formed integral with the holder-guide 120 and the V-ways 121, removably and adjustably secured to the said holder-guide, the latter guide being removably and vertically adjustably secured to the tail-stock 9, hereinbefore described.

To the holder 120 is secured the lever-stud 122, adapted to neatly fit the slot 123, formed in the operating-lever 124, said lever fulcrumed to the tail-stock 9 by the fulcrum-bolt 125.

126 designates the usual cone-centering device provided with the integral supporting-arms 127, removably secured to the slide-rods 128 by suitable clamping-nuts 129, said sliding rods adapted to slide longitudinally backward and forward in suitable ways or holes formed in the head-stock 2, and having their opposite or free ends rigidly connected by the bar 130 and the clamping-nuts 129.

The operation of my invention is as follows: The wood to be turned (whether rectangular or polygonal in form) is first centered on the machine, one end of which is set in and against the centering-cone 126, while the other end is centered on the center 9^a of the tail-stock 9. The tail-stock hand-wheel 9^b is rotated till the end of the wood to be turned is forced against the rotating center "bit" of the head-stock 2. The roughing-bit, its holder 80, and frame 86 are previously moved to either of the extreme ends of the slide-bar 97, on which it is pivoted. The pulley 6, being rotated by a driving-belt at the required speed and in the usual way, produces a like rotation to its attachments and the center bit 7 attached thereto and the wood to be turned contacting therewith. Having adjusted either of the roughing-bits 78 and 79 in their holder 80 and set the contour-former 96 in its relative position to the holder-frame knife 93, the operator embraces the handle 86^a to move frame 86 along its

guides, care at the same time being taken to keep the knife-edge thereof in close contact with the said contour-former 96, thus forming the wood to the desired pattern—that is, to the contour of the former used. It is obvious that the V-cuts, as at *a*, (see Fig. 12,) cannot be formed by the usual half-round tool. This finishing operation I perform by the specially-formed bits or cutters 54, which are pivoted in the manner hereinbefore described and secured to the supporting-table 40, and are raised up or down by the operating-wheel 39 and backward and forward by the manual wheel 63, as hereinbefore described.

From the foregoing it is clear that the wood to be operated upon can be inserted into and removed from the lathe without stopping the rotation of the rotating center.

In the drawings, for the sake of clearness, I show only one of the finishing-tools and its holder; but it is obvious that for such a column as that shown in Fig. 12 five such finishing-tools would be required to be used. It is also obvious in this class of lathe that the cutters 78 and 79, owing to the raised portions of the "former" 96, will readily turn such a column as shown in Fig. 12 without permitting the tool to touch the corners of the rectangular parts *b*, *c*, and *d*.

When it is necessary to turn a "rosette" or such other ornaments as are formed from the flat surfaces of rectangular wood blocks, I center the block in the usual way on the head-stock center, move the tail-stock along the way to a convenient working distance from the head-stock, and firmly secure the said tail-stock thereto. All that is required to be done is to slide the rosette-bit 115 by means of its operating-lever 124 until the said bit contacts with the wood to be turned, which having been finished or completely cut, the said bit is slid back or withdrawn and the work removed from the center.

I am aware that previous to my invention gage-lathes having formers or gages whereby the cutting-tools have been guided to suit the contour of the required design have been used. This I do not claim, broadly, as my invention; but

What I do claim, and desire to cover by Letters Patent of the United States, is—

1. In a wood-turning lathe, the combination, with the pivotal tool, its guide, and contour-former, of the vertically-adjustable contour-former supporter, suitable outer adjustable guide-supporting bars, upper swinging arms pivoted to the said contour-former and guide-supporting bars at or near their summits, and suitable bottom supporting-arms extending from the frame of the lathe and whereto the said guide-supporting bars are adjustably secured, substantially as and for the purpose set forth.

2. In a wood-turning-lathe, the combination, with the pivotal tool, its guide, and contour-former, of the vertical adjustable contour-former supporters, suitable outer adjustable guide-supporting bars, upper swinging arms pivoted to the said contour-former and guide-supporting bars at or near their summits, suitable bottom supporting-arms extending from the frame of the lathe and whereto the said guide-supporting bars are adjustably secured at the outer ends of said arms, and suitable means whereby the bars may be moved independently, substantially as and for the purpose set forth.

3. In a wood-turning lathe, the combination, with a suitable finishing-bit 54 and the arm 55, whereto said bit is secured, of the supporting-standards 52, whereto the said arm is pivoted, the table 16, the screw-threaded standards 23 and 24, and the sliding table 40, whereby the said tool is moved backward and forward and upwardly and downwardly while the machine is in motion, substantially as shown and described.

4. In a wood-turning lathe, the post 66, and steadying-rest 64, chambered to receive the said post whereon the head 68 is formed, with the rectangular opening 69, in combination with the table 58, clamping-screw 67, set-screw 71, and the rest 70, located in the said rectangular opening, substantially as shown and described.

In testimony whereof I have hereunto set my hand in the presence of two subscribing witnesses.

PETER NEWMAN.

Witnesses:

T. R. BELL,
GEORGE MASSONNE.